

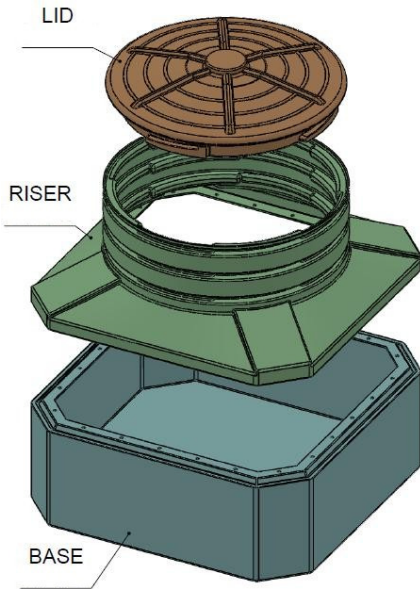

ChamberTite Large DrawPits



Forecourt Solutions are pleased to announce the availability of our own **ChamberTite** 1150 x 1150 mm wide base Drawpits. The **ChamberTite** large drawpit provides a watertight vacuum testable chamber for all your cabling connections with variable height options between 630 and 1730mm. Ideally suited for installation below our CC0900V2 D400 rated lightweight watertight composite manhole cover the chamber has a riser width of 808 mm provides excellent access to cabling for maintenance. Base dimensions are designed to minimise freight costs and are available in 1150 x 1150 mm as standard. Other dimensions available upon request. The three part chamber consists of a base, adjustable height riser and watertight lid. Manufactured from strong rotationally

moulded polyethylene the chamber will not corrode, is easy to cut down to suit site burial depths and drill to fit watertight **ChamberTite** duct and conduit entry boots. Entry boot seals can be provided for your duct and electrical cabling entry requirements.



Electrical Draw Pits



Pipe & Cable Entry Boots

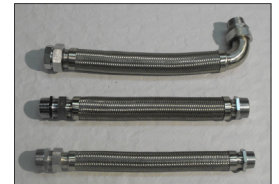

Flexible Hose Assemblies

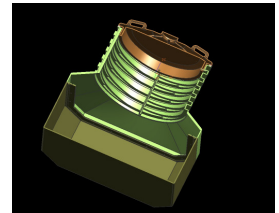

Tank & Dispenser Sumps



Forecourt Manhole Covers



Covers Lift Sticks

Large DrawPit Height Ranges
(Excluding Lid)

Shallow base (400 mm) — 630, 730, 830mm

Medium base (650mm) — 880, 980, 1080 mm

Each riser has three height adjustment levels. Should deeper chambers be required please ask. Chambers can be manufactured in your preferred colour to order or are available as standard in yellow.

The DrawPits can be installed beneath our own Composite Covers 900 mm clear opening lockable watertight manhole cover or can be equally installed beneath traditional cast iron non watertight covers as the chamber comes complete with its own watertight lid.

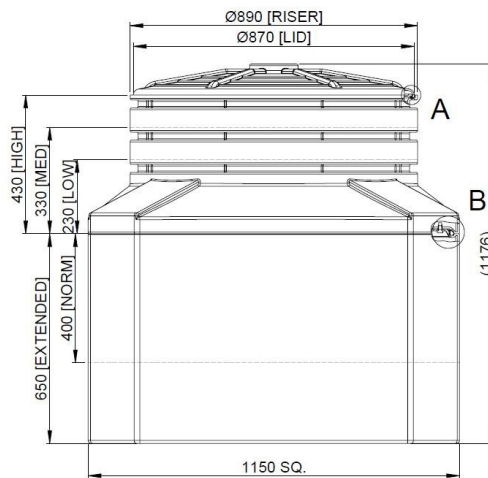

Forecourt Solutions Ltd
Unit F, Thistle Park,
Crossways Road,
Showground Business Park
Bridgwater, Somerset,
TA6 6LS, UK.

T: +44 (0) 1278 42 88 33
F: +44 (0) 1278 45 98 08
E: Info@forecourtsolutionsltd.com
W: www.forecourtsolutionsltd.com
Registered in England & Wales No 5669793
VAT Reg. No: 879 904263

